

NORNDA AUTOMOTIVE

Assembly Instructions

To Suit : Ford Falcon

25-31 Innes Road
Windsor Gardens
Australia SA5087
Ph + 61 8 8261 7222
Fx + 61 8 8261 9171

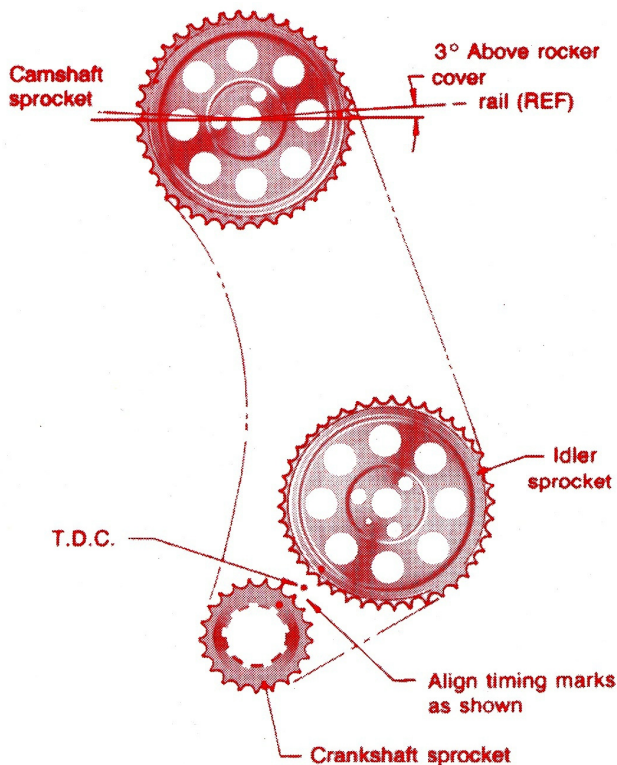

Diagram A

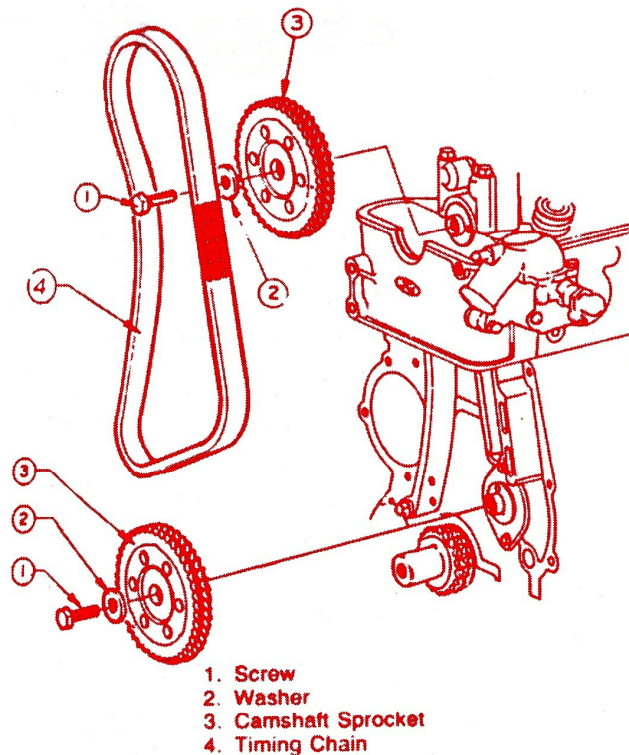

Diagram B

Note: All bolts (Part Number 1 in Diagram B) are torqued to 80Nm. The timing mark on the camshaft sprocket may be up to 3.0mm above the rocker cover rail.

When installing threads apply PermaBond A115 or equivalent to the thread.

It is advisable to have a good workshop manual to complete this installation.

Warning: Do not use the keyway marks to time engine. Always align crank sprocket and tooth timing mark to idler sprocket.

Ensure chain clips faces away from the engine block and the closed end of the spring clip faces the direction of rotation.

Lubrication: For maximum chain life, proper chain lubrication is necessary. When R.P.M. increases, chain lubrication must also increase. In order to reduce wear, a good lubricant must form a film over the contacting surfaces. Excessive wear can cause the chain to lengthen to the point of damaging sprocket teeth and destroying the timing chain drive.

Standard Timing

1. Assemble the upper damper (channel) to the chain. Pass the chain through the cylinder head. Position the camshaft sprocket in the chain.
2. Align the timing marks on the crankshaft and the idler sprockets. (see Diagram A). Install the chain on the sprockets.
3. Walk the camshaft sprocket along the chain to align the timing mark on the sprocket to the cylinder head rail (see Diagram A). Install the sprocket on the camshaft ensuring that the sprocket locating pin engages in the notch in the camshaft (see Diagram B). Install the bolt and washer.
4. Install the upper damper bolt.
5. Install the pivot bolt thread and the lower (tensioner controlled) damper.
6. Check the valve timing and the auxiliary shaft (idler) timing.
7. Install the rocker arm cover and timing cover.

Advanced Timing

(+2° +4° +6°)

Note: We recommend to always degree- in the camshaft before making any timing changes.

1. Follow standard timing installation instructions until step 2.
2. Fit crankshaft sprocket to crankshaft, ensuring that the keyway selected is aligned to the crankshaft keyway.
3. Rotate the crankshaft anti-clockwise until the same advance position on the outer sprocket is aligned with the timing mark on the idler sprocket.

Retard Timing

(-2° -4° -6°)

Note: We recommend to always degree- in the camshaft before making any timing changes.

1. Follow standard timing installation instructions until step 2.
2. Fit crankshaft sprocket to crankshaft, ensuring that the keyway selected is aligned to the crankshaft keyway.
3. Rotate the crankshaft clockwise until the same advance position on the outer sprocket is aligned with the timing mark on the idler sprocket.