

NORNDA AUTOMOTIVE

Assembly Instructions

25-31 Innes Road
Windsor Gardens
Australia SA5087
Ph + 61 8 8261 7222
Fx + 61 8 8261 9171

To suit: Ford Windsor V8

Warning:

Do not use the keyway marks to time the engine. Always use the tooth or tooth space timing marks.

Note:

Check for clearance between timing components and block or timing cover. On some blocks it may be necessary to remove material for chain or sprocket clearance. Before advancing or retarding the camshaft timing, the camshaft timing should be checked in the standard position with a degree wheel.

Lubrication:

For maximum chain life, proper chain lubrication is a necessity. When increasing the timing chain speed (rpm's), lubrication of the chain must also increase. Therefore, oil must penetrate into the spaces between the link plates thereby sufficiently lubricating the bearing surfaces between the pins and the bushes. Excessive wear can cause the chain to lengthen to the point of not only damaging the sprocket teeth but destroying the timing chain drive.

- 1 Standard Timing**
Slide 'O' keyway onto crankshaft key and time engine by using the 'O' marked tooth or space.

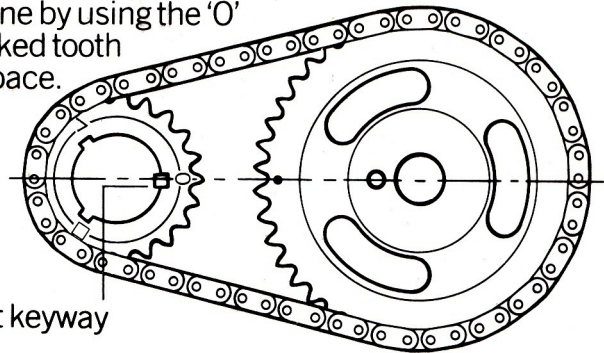

- 2 Advanced Timing**
Slide keyway marked one of the three ways '+4', 'A' or 'Δ' onto crankshaft key and time engine using tooth or space marked one of three ways '+4', 'A' or 'Δ'. Advanced timing will increase low end torque.

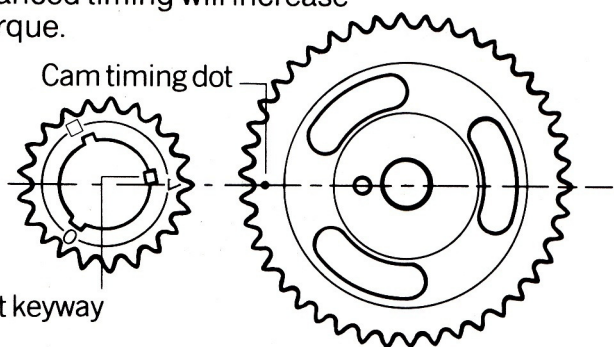

- 3 Retarded Timing**
Slide keyway marked one of three ways '-4', 'R' or '□' onto crankshaft key and time engine using tooth or space marked one of three ways '-4', 'R' or '□'. Retarded timing will increase top end horsepower.

