

NORNDA AUTOMOTIVE

25-31 Innes Road
Windsor Gardens
Australia SA5087
Ph + 61 8 8261 7222
Fx + 61 8 8261 9171

Fitting Instructions To suit - Holden V8

1

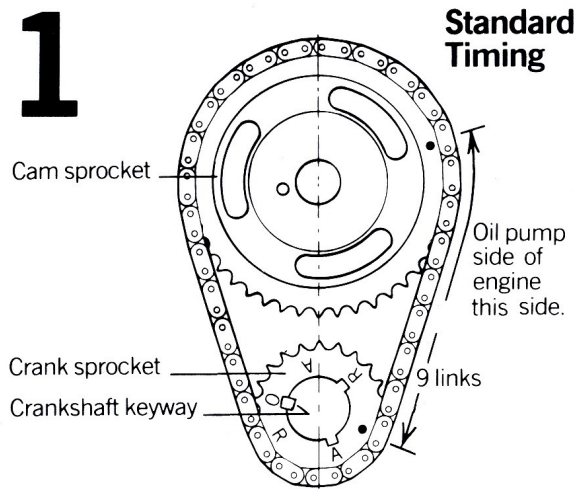

Rotate engine until No. 1 piston is Top Dead Centre (T.D.C.) compression stroke. No. 1 piston is located at front of engine on drivers side. Assemble crankshaft sprocket, camshaft sprocket and chain so that zero timing dots are positioned as shown above. (9 links between dots).

2

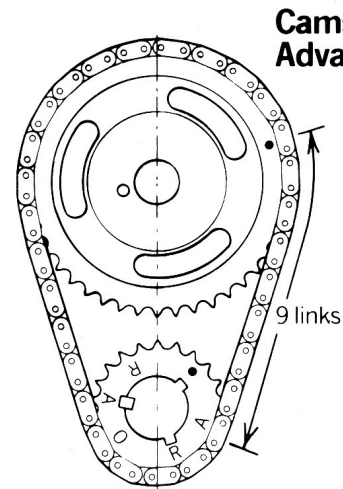

Same as for instruction No. 1, but fit crankshaft sprocket keyway marked 'A' to crankshaft and align Tooth marked 'A' on crankshaft sprocket and timing dot on camshaft, so there are 9 links between them. As shown above.

3

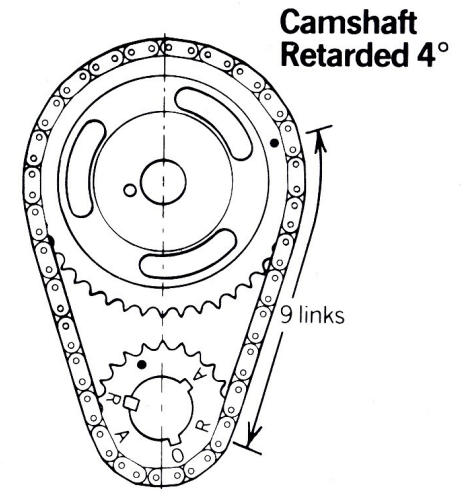

Same as for instruction No. 1, but fit crankshaft sprocket keyway marked 'R' to crankshaft and align Tooth marked 'R' on crankshaft sprocket and timing dot on camshaft, so there are 9 links between them. As shown above.